



304 Smokey Lane North Little Rock, Arkansas 72117 Phone: (501) 945-0354 FAX: (501) 945-0370
www.StreetandPerformanceElectronics.com

Coil Covers

Installation Instructions

(1999-2002 Chevrolet Camaro/Pontiac Firebird 5.7L LS1 Part # 665022)

Important! Read all instructions before you begin installation.

Thank you for purchasing the Street & Performance Electronics Coil Covers. Please check to make sure all the parts are included with your kit.

Assembly is quite easy and straightforward. You will attach the cover anchor brackets to already available attaching points with the provided nuts and washers. And with the DZUS fasteners already installed in the covers a quick 1/4-turn with a Phillips #1 driver makes the assembly that easy.



Parts List

- | | |
|--------------------------------|-------------------|
| 1 Coil Cover (Left) | 6 DZUS lock clips |
| 1 Coil Cover (Right) | 6 6mm washers |
| 6 Coil Cover Locating Brackets | 6 6mm nuts |

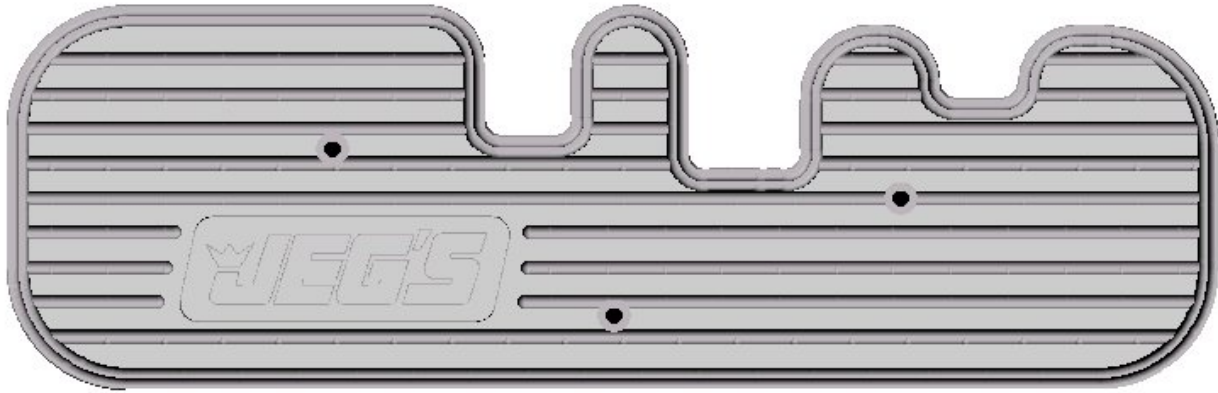

PASSENGER-SIDE COIL COVER

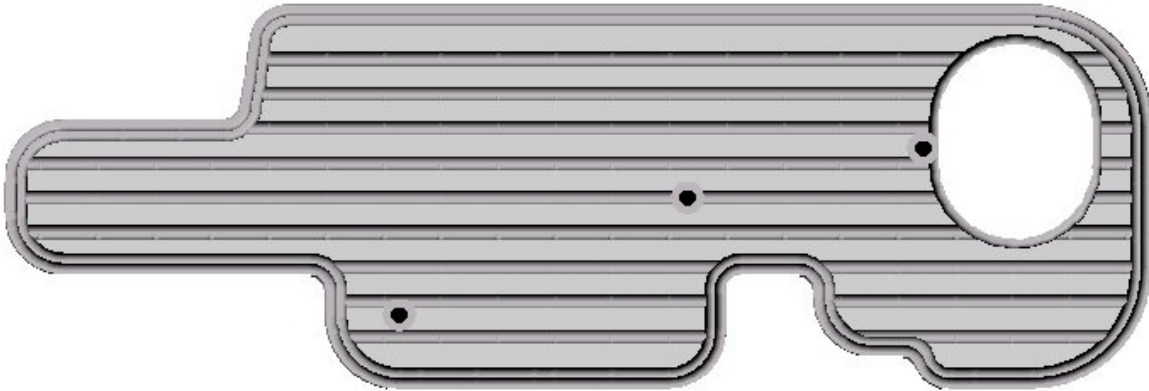

DRIVER-SIDE COIL COVER

Driver's-Side:

1. If equipped, loosen and remove the Secondary Air Injection (AIR) tube from exhaust manifold.
2. Disconnect the coil pack plug. Release the EVAP Canister Purge Valve Solenoid (EVAP) from bracket. Release EVAP line from solenoid (squeeze the plastic retainer release tab and pull line from solenoid).
3. Assemble the DZUS clips onto the locating brackets. Situate clip that its flush against the flat portion of the locating bracket.
4. Attach **Coil Cover** locating brackets to coil bracket locations listed in illustration below using supplied nuts and washers.
5. Lift fuel/EVPA supply lines upward, while guiding the **Coil Cover** into position. Take care as to not scratch the cover on sharp corners. Maneuver the cover into position above the mounting tabs.
6. Attach **Coil Cover** to locating brackets using the 1/4-turn DZUS fasteners.
7. Apply a few drops of clean engine oil to the male fuel pipe end of EVAP solenoid. Push both sides of the quick-connect fitting together in order to cause the retaining tabs/fingers to snap into place.
8. Connect the AIR pipe to the exhaust manifold. Tighten the AIR pipe to the exhaust manifold to 20 Nm (15 lb/ft). You might have to "tweak" the tube to provide adequate clearance.

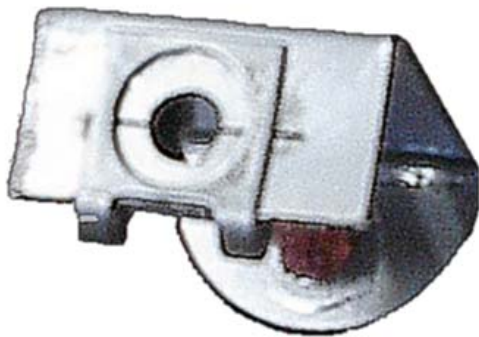

Passenger-Side:

1. Remove oil filler cap. Remove oil dipstick gauge (not the tube). Disconnect the Exhaust Gas Recirculation (EGR) valve harness.
2. If equipped, loosen and remove the Secondary Air Injection (AIR) tube from exhaust manifold.
3. Assemble the DZUS clips onto the locating brackets. Situate clip that its flush against the flat portion of the locating bracket.
4. Attach **Coil Cover** locating brackets to coil bracket locations listed in illustration below using supplied nuts and washers.
5. Guide **Coil Cover** into position. Maneuver the cover into position above the mounting tabs.
6. Move cover upwards to gain access to the AIR tube. Connect the AIR pipe to the exhaust manifold. Tighten the AIR pipe to the exhaust manifold to 20 Nm (15 lb/ft).
7. Attach **Coil Cover** to locating brackets using the 1/4-turn DZUS fasteners. You might have to "tweak" the AIR and oil dipstick tube to provide adequate clearance.
8. Reconnect the EGR valve harness. Reinstall the oil dipstick gauge. Reinstall the oil filler cap.

